

Ocean 1 (3 doors)

Running part and guiding part of outer door
/ Lauf- und Führungswagen Türe außen

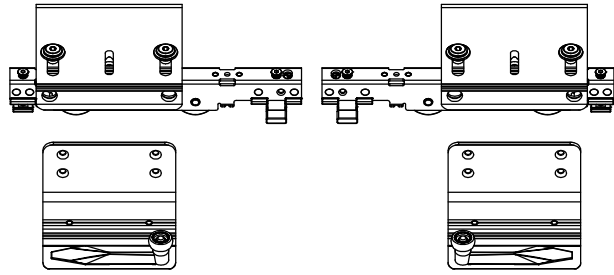

Damper
/ Dämpfer

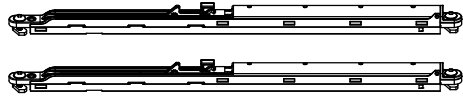

Two-way damper (front door)
(alternative)
/ Zweiwege Dämpfer

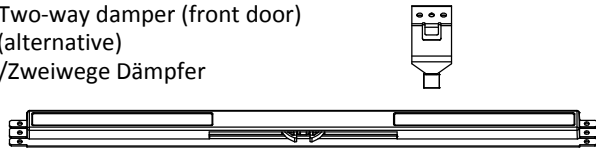

Running part and guiding part of inner door (left)
/ Lauf- und Führungswagen Türe innen (links)

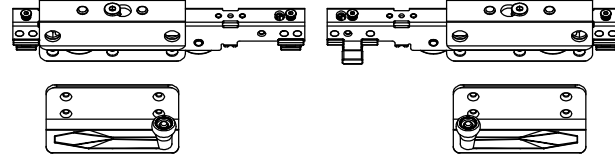

Running part and guiding part of inner door (right)
/ Lauf- und Führungswagen Türe innen (richtig)

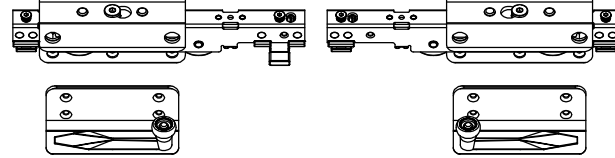

Running track
/ Laufschiene



Guiding track
/ Führungsschiene

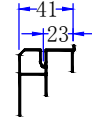

Cabinet door width calculation
/ Schrank Türbreitenberechnung

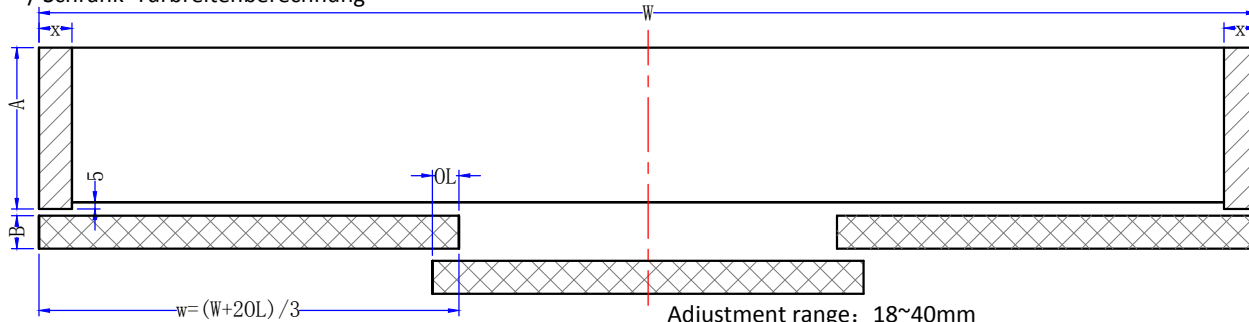

Adjustment range: 18~40mm
/ Einstellung Bereich: 18-40mm

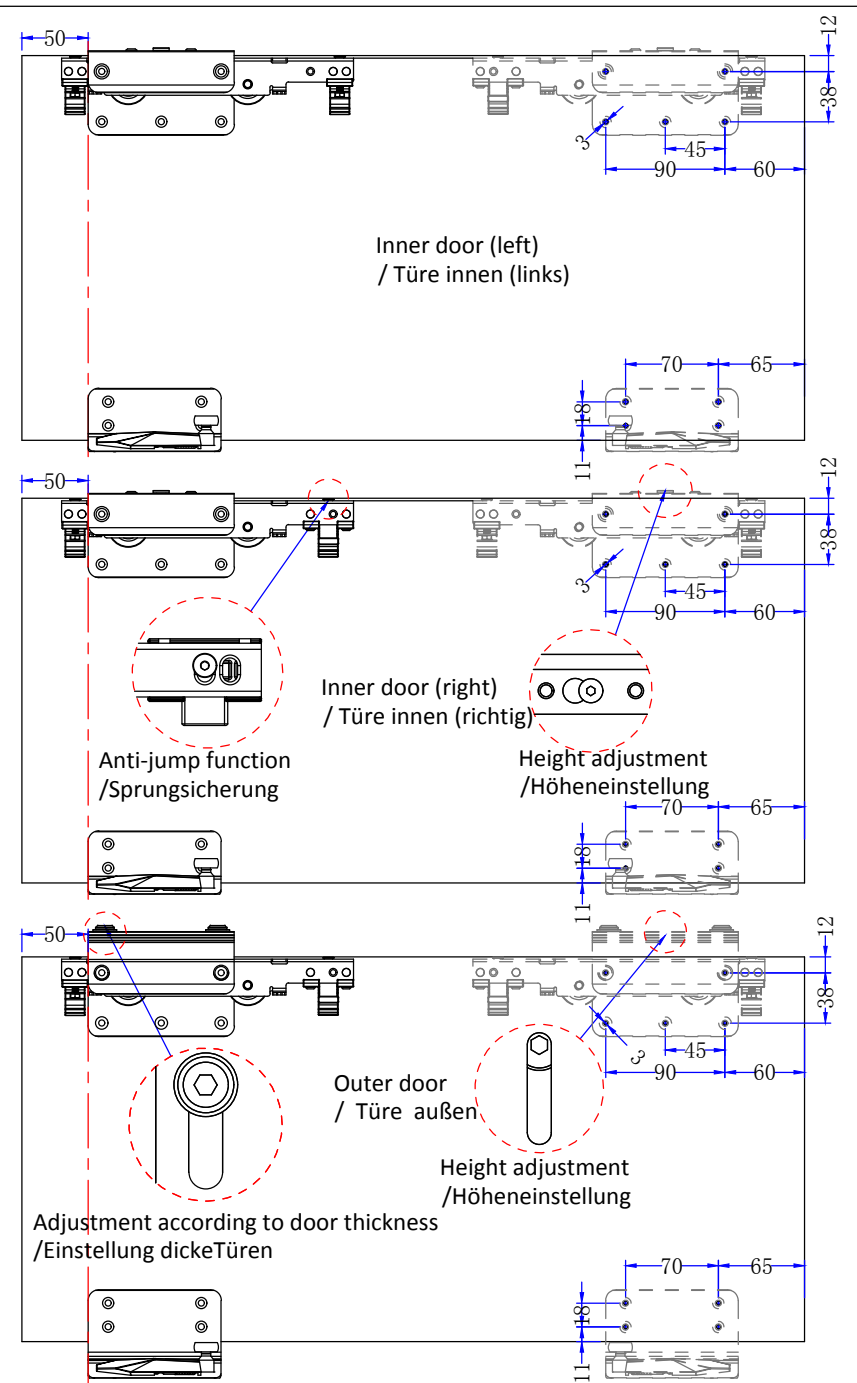
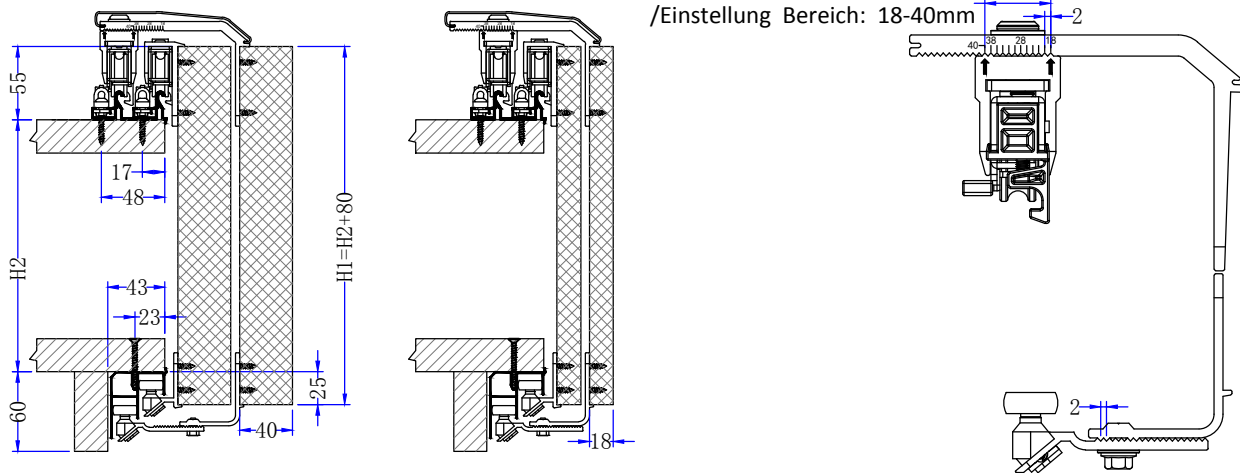

<p>OPK Europe GmbH Junghansstraße 16 72160 Horb am Neckar</p>	<p>Ocean 1</p> <p>Creator: LXJ</p>	<p>Name: Ocean 1 (3 Doors)</p>	
	<p>Description: Application for wooden door, framed door, Aluminum-framed door. Door panel installation height is adjustable.</p>	<p>Ratio/Verhältnis: 1:4</p> <p>Date/Datum: 02/27/19</p>	<p>Format: A3</p> <p>Page / Seite: 1/1</p>
	<p>We reserve the right to make changes. We do not accept rifles.</p>		